

Contents

GENERAL INFORMATION	2
1. Documentation supplied with the machine	2
2. General notes	2
3. Important safety notes	3
GETTING TO KNOW YOUR MACHINE	4
1. Control panel	4
2. Installation data	4
INSTALLATION	5
1. Glossary	5
2. Unpacking the appliance	6
3. Positioning	6
4. Connections	6
5. Dispenser settings	8
6. Operator training	10
USE AND MAINTENANCE	11
1. Safety notes	11
2. Preparation of the machine	12
3. First cycle	13
4. Subsequent cycles	14
5. Emptying the machine	15
6. Before the daily shutdown	15
7. Maintenance	15
8. Regeneration	16
9. Solutions to the most common problems	19
SERVICING AND REPAIR	21
1. Safety notes	21
2. Resetting the safety thermostat	21
3. Renewal of the peristaltic dispenser pipe (optional)	22
DEINSTALLATION	23

GENERAL INFORMATION

FAILURE TO COMPLY WITH THE INSTRUCTIONS PROVIDED MAY COMPROMISE THE SAFETY OF THE APPLIANCE AND WILL INVALIDATE THE WARRANTY WITH IMMEDIATE EFFECT.

1. *Documentation supplied with the machine*



This manual contains important information regarding safety during the installation, use and maintenance of the appliance. To ensure that you obtain the maximum safety, hygiene and performance, keep all the documents supplied in a safe place near the appliance and ensure that they are available for consultation by all the personnel assigned to the installation, operation and maintenance of the machine.

I **Manual**

This manual is divided into various sections and contains instructions covering the entire service life of the appliance:

- installation reserved for qualified technicians
- use and maintenance addressed to the user
- repairs reserved for qualified technicians
- deinstallation reserved for qualified technicians

II **Technical documentation**

In addition to this manual, the following documents are supplied with the appliance:

- electrical circuit diagram
- layout diagram

2. *General notes*

The quality of this machine is ensured by the use of high-quality materials, construction according to EC safety directives and by fully testing each appliance.

- Adherence to the recommendations contained in this manual **is essential for the safety** of the installation and the user.
- The manufacturer, the dealer and the authorized service centers are available for any further clarification regarding the use and installation of the appliance.
- The manufacturer reserves the right to make any modifications to the appliance deemed necessary without prior notice.

GENERAL INFORMATION



3. *Important safety notes*

The appliance is designed for professional use and notwithstanding the manufacturer's efforts to simplify its operation, installation and maintenance, the appliance is **designed for operation by trained personnel** in compliance with the manufacturer's instructions. Do not allow children to operate or play with the machine.



Failure to comply with the manufacturer's instructions contained in the documentation supplied with the machine may compromise the safety of the appliance and will render the warranty void with immediate effect.

THE MANUFACTURER ACCEPTS NO LIABILITY FOR ANY DAMAGE TO OBJECTS OR PERSONAL INJURY ARISING FROM FAILURE TO COMPLY WITH THE INSTRUCTIONS PROVIDED.



THE FOLLOWING OPERATIONS ARE EXPRESSLY PROHIBITED:

- The installation or deinstallation, maintenance, adjustment, repair of the appliance or any other type of operation which requires the removal of the protective panels, unless **carried out by qualified and authorized personnel** in compliance with the manufacturer's instructions; such persons must always disconnect the machine from the electrical power supply and the water supply before undertaking any such operation and take the necessary precautions if they exclude the safety devices installed by the manufacturer.
- **Installations of an inferior standard or temporary nature** or any installation in which adequate protection is not provided for the electrical power supply (e.g. fuses, main switch, **EARTH CONNECTION**) or the water supply (e.g. stop cock, waste trap).
- **Modifications or the installation of additional devices** which alter the operation of the machine.
- **Use of non-original replacement parts.**
- Installation or repositioning in environmental conditions which do not comply with the manufacturer's prescriptions.
- Use of the appliance to wash items of a type or size other than that prescribed by the manufacturer.
- Use of corrosive, impure or dry products in the dispensers.



The servicing and repair of the machine must be carried out by qualified and authorized technicians only.

GETTING TO KNOW YOUR MACHINE

1. *Control panel*



[1] = Power on/off switch and pilot light»



[2] = Start button



[3] = “Wash cycle” pilot light



[4] = “Heating” pilot light



[5] = Cold rinse (optional)



[6] = Drain pump (optional)



[7] = Cycle selection (optional)

2. *Installation data*

For correct installation, follow all the instructions in the section “Installation”.

All the data necessary for correct installation of the appliance can be found on the data plate affixed to the machine. A copy of this data plate is printed on the cover of this manual for quick reference.

 **The appliance must be installed correctly in order to function properly. Installation of the appliance should be carried out by qualified and authorized technicians only.**

INSTALLATION

THE MANUFACTURER ACCEPTS NO LIABILITY FOR ANY DAMAGE TO OBJECTS OR PERSONAL INJURY ARISING FROM INSTALLATIONS WHICH FAIL TO COMPLY WITH THE INSTRUCTIONS PROVIDED.

1. Glossary

 In this document, the terms **Main switch**, **water supply stop cock** and **Drain line** are defined as follows:

MAIN SWITCH:

Must be of the type which **disconnects all conductors of the supply circuit including the neutral**, with a distance between the open contacts of at least 3 mm, incorporating a thermal magnetic circuit breaker or fuses, to be sized or calibrated in accordance with the power rating indicated on the appliance data plate.

The main switch must be located near to the installation and **must serve only one machine.**

WATER SUPPLY STOP COCK:

This must be a slide, ball or gate stop valve **capable of rapid and complete shut-off of the water supply**, of sufficient dimensions to ensure the flow rate and pressure indicated on the machine data plate.

If the water supply pressure exceeds the prescribed maximum, a pressure regulator must be installed upstream of the machine. If the supply pressure is below the prescribed minimum, a pressure booster pump must be installed upstream of the machine.

If the temperature of the incoming water is below the recommended minimum, additional steps must be taken to obtain good washing results (see chapter “USE AND MAINTENANCE”)

The stop cock must be installed on the water supply pipe near to and **immediately upstream of the appliance.**

DRAIN LINE

Must comprise an **open trap** of sufficient dimensions to discharge at least double the required supply flow.

It must be installed within reach of the discharge pipe supplied with the machine without this being subject to **tension, kinking or joints.**

INSTALLATION

2. *Unpacking the appliance*

Before removing the packaging, check for any signs of damage, noting any defects found on the carrier's delivery note

After removing the packaging **inspect the appliance for signs of damage**; if damaged, notify your dealer by fax or registered post immediately and, if the damage is such as to compromise the safety of the machine, **do not** proceed with the installation until the appliance has been checked by a qualified technician.

⚠ Packing materials (plastic bags, expanded polystyrene, nails, etc.) must not be left within reach of children and pets as they potentially very dangerous.

3. *Positioning*

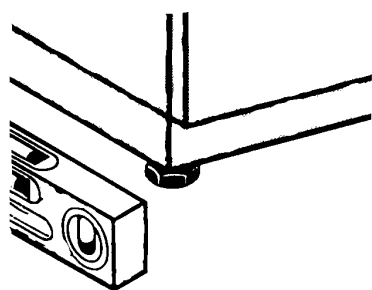

Ensure that there are no objects or materials near the installation site which could be damaged by water vapor or splashes of detergent solution which might be produced by the machine during operation.

The appliance must be leveled using the four adjustable feet so that it is **perfectly stable**; any other type of installation must be agreed and approved by the manufacturer.

4. *Connections*

I **Electrical supply**

A **Main Switch** must be provided for connection (see "Glossary").

⚠ There must be an efficient EARTH CIRCUIT to which the machine is to be connected.

⚠ Do not use adapters, multiple sockets, cables of insufficient cross-sectional area or with extension connections which do not comply with specifications prescribed by EN 60335-1 and EN 60335-2-58.



- **The electrical power supply** must be compatible with the indications on the data plate. For details on electrical operation consult the electrical circuit diagram.
- **The supply cable** must not be pulled or crushed during normal operation or routine maintenance.
- **The equipotential bonding terminal** fixed to the body of the machine must be connected in accordance with the requirements of standards EN 60335-1 and EN 60335-2-58 (using a cable with a cross-sectional area of between 2.5 and 6 mm²)

INSTALLATION

II Water supply

A water supply pipe with a **“Stop cock”** (see “Glossary”) must be provided for each machine.

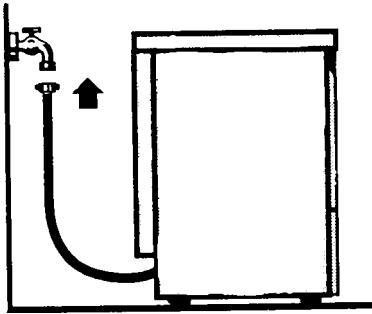

The water supply line must conform to the specifications indicated in the section “Installation data”, even when other appliances are connected to the supply line.

If the water supply system **is new or has not been used for a prolonged period, run the water before connecting the appliance** so as to eliminate any impurities or air pockets which could soil or damage the machine.

Connect the filling solenoid valve to the stop cock with a flexible pipe.

III Drain line

A suitable **“Drain line”** must be provided (see “Glossary”).

To ensure unrestricted discharge the pipe must reach the trap **without being put under tension, kinked, crushed, pressed or forced.**

For machines with optional “drain pump” only.

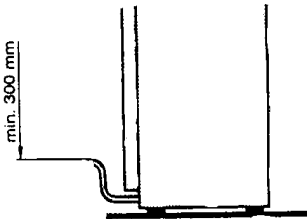

If the discharge pipe is connected to a trap in the floor, the highest point of the pipe must be at least 300 mm above floor level to prevent the machine from emptying.

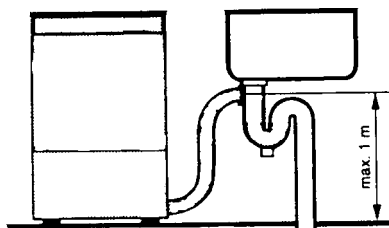

The highest point of the discharge pipe should be less than 1 meter above floor level.

INSTALLATION

5. *Dispenser settings*

I **Rinse-aid dispenser**

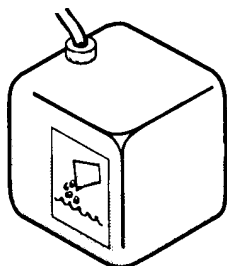

Before starting the washing cycle, the dispenser and the delivery pipe must be full.

Check that there is sufficient rinse-aid in the container and top up if necessary.

The rinse-aid container must never be allowed to empty completely and must not be topped up with corrosive or impure products.

! The warranty does not extend to any damage arising from incorrect use of the dispenser.

The dispenser is **not** factory-set; the dispenser must be calibrated by a qualified technician.

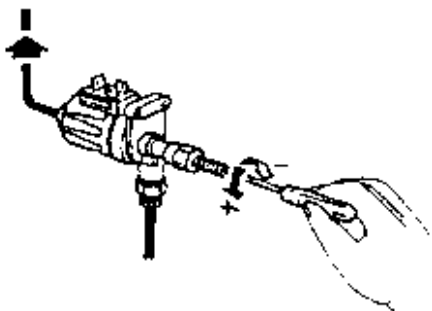

The dispenser is calibrated by adjusting a screw which is accessed by removing the front panel under the wash chamber door.

With the panel removed, without pulling the connection pipe, fill the delivery pipe with rinse-aid, and then fully close the adjuster screw, without forcing.

To determine the dosage for the preliminary setting, **refer to the information provided by the product manufacturer.**

Once you have determined the required dosage, open the adjuster screw until this quantity is obtained.

Electric dispenser (DB-2)

One full turn of the adjuster screw is approximately equivalent to 0.06 grams of product per dispenser pulse, given that when fully open (16 turns of the screw), the dispenser delivers 1 gram/pulse. If the machine has 3 pulses per cycle, it can thus dispense from a maximum $3 \times 1 = 3$ grams/cycle (16 turns of the screw) down to a minimum of $0.06 \times 3 = 0,18$ grams/cycle (1 turn of the screw).

After this preliminary calibration, any subsequent adjustment is to be made on the basis of the rinsing results obtained after at least 3 cycles.

Turn the screw counter-clockwise to increase and clockwise to reduce the dosage.

Bluish streaks on dishes and the formation of foam in the washing solution indicate too much rinse-aid.

Drops of water on items and slow drying indicate too little rinse-aid.

! In the event of imperfect washing, (at incorrect temperature or with too little detergent), an invisible, non-toxic patina of grease or starch may form on the tableware. This patina will prevent the rinse-aid from doing its job properly and in this case, increasing the dosage of the rinse-aid will

INSTALLATION

not lead to any significant improvement. To remove this patina, the tableware is to be left to soak in a water and soap solution (10:1) for about 30 minutes and then washed again.

II Detergent dispenser (optional)

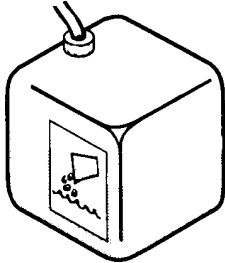

Never allow the detergent container to empty completely and never top up with corrosive or impure products.

⚠ The warranty does not extend to damage arising from incorrect use of the dispenser.

The detergent dispenser is factory-set; any subsequent adjustment to the dispenser setting should be carried out by a qualified technician.

⚠ Refer to the dosage indicated by the detergent manufacturer, taking into account:

- characteristics of the water in your area;
- the type of items to be washed: glass, plastic, ceramic, decorated or plain porcelain, metal, cutlery or cooking utensils;
- type and quantity of food residue;
- intensity of use (number of wash cycles per hour).

Electronic dispenser EV-400

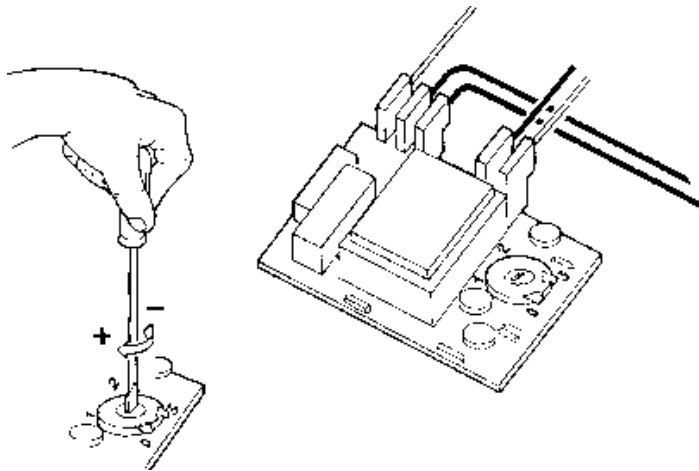

Carefully clean the machine.

Adjust the detergent potentiometer on the electronic control card (consult layout diagram), turning it fully counter-clockwise to obtain zero detergent dosage.

Start a wash cycle, with no dishes in the machine, and allow the chamber to fill with water.

INSTALLATION

On completion of the filling cycle and before the wash cycle has started, open the door and pour the previously determined quantity of detergent into the chamber in the region of the wash pump suction filter.

About 10 seconds after the start of the wash cycle, start turning the potentiometer in a clockwise direction until you hear a buzzing which indicates that the dispenser is delivering detergent to the chamber. At this point the dispenser is calibrated to the previously determined dosage.

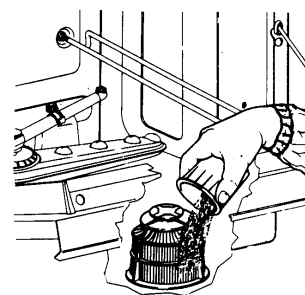

Any subsequent adjustment to the dosage should be made on the basis of the results obtained after a number of real wash cycles **(turn the potentiometer clockwise to increase the dosage and counter-clockwise to decrease it.)**.

6. *Operator training*

 The installer is required to **provide the users with suitable instruction on the operation of the appliance and on the safety precautions**. He/she must also give practical demonstrations of the use of the appliance and ensure that he/she is in possession of all the documentation supplied with the appliance.

Note that to obtain the best performance and longest service life from the appliance, it must be used **in accordance with the operating instructions**, which must be kept in a safe place, **with particular attention to maintenance** (routine, periodic and major) and to periodic sanitation using non-corrosive commercial products.

USE AND MAINTENANCE

1. Safety notes

THE MANUFACTURER ACCEPTS NO LIABILITY FOR ANY DAMAGE TO OBJECTS OR PERSONAL INJURY ARISING FROM FAILURE TO COMPLY WITH THE INSTRUCTIONS PROVIDED.

I Precautions

 The correct operation and the service life of the appliance depend on external factors including **preventive maintenance**, the characteristics of the water supply and the products used for washing, rinsing and cleaning.

 **Maintenance should be carried out at the recommended intervals and in the manner prescribed.**

The characteristics of the water supply (in particular the hardness and pressure) are the main factors to be taken into consideration when deciding whether or not to install an additional rinse pump, water softener, filters or purifiers to improve washing results or reduce detergent consumption. Consult your installation technician for advice.

II Safety

 **In case of malfunction, seek assistance from qualified and authorized technicians only.**

 Prior to all maintenance, adjustment, repair and cleaning operations and in the case of malfunction, **always disconnect the appliance from the electrical power supply** at the external main switch, and **shut off the water supply** at the supply tap.

 **Do not** clean the appliance using:

- pressurized water jets, as water could get into the electrical system and damage it;
- scouring pads, wire brushes or corrosive or abrasive cleaning products which could damage surfaces and rubber parts.

A soft damp cloth with a small quantity of detergent is all that is required to get the appliance perfectly clean.

III Warnings regarding use of the appliance

- **NEVER** open the door before the cycle has terminated and the machine has stopped to prevent the possibility of splashes of alkaline washing solution being thrown out of the machine and to allow the moving parts to come to a complete stop.
- **NEVER** climb or stand on any part of the appliance or use it as a support for objects or animals.
- **NEVER** overload the open door of a front-loading appliance; the door is only designed to support the weight of the rack loaded with tableware.
- **NEVER** use the machine to wash items of a type, shape, size or material not compatible with the manufacturer's recommendations..

We recommend that you do not wash items which are not guaranteed suitable for dishwashers or which are cracked or fragile through use.

IV Hygiene

 **To ensure the hygiene of the machine, it is important to carry out the periodic maintenance operations** indicated in the relative section of this manual. The appliance must also be regularly **sanitized** using suitable non-corrosive commercial products.

The internal components of the appliance should be periodically cleaned and checked by a qualified technician.

 To ensure the **hygiene of the tableware**, apply the following basic rules:

- **remove dry or solid food particles** from items before washing;
- **change the washing solution**, in accordance with the number of cycles performed, but always **at least three times a day**;
- to avoid contamination of clean tableware **do not use: rotary brushes, dish cloths or tea towels which are not sterile**, or place washed items on sponge or other materials which may be contaminated with bacteria. **Use disposable materials or draining racks**;
- **frequently clean all surfaces** where dishes may be placed, using commercial disinfectant products.

2. Preparation of the machine

I Detergents

 **The type and quantity of detergent used determine the washing results obtained from the appliance and the length of its service life.**

Detergents are not supplied with the appliance; we suggest that you contact a reputable detergent manufacturer who can advise you on the type of detergent suitable for your particular requirements. Use the dosage recommended by the detergent manufacturer; incorrect dosages may give unsatisfactory results or cause unnecessary pollution.

To avoid damage to the appliance and to protect the environment, do not use corrosive or pollutant products.

The appliance uses **two types of detergent**:

- Washing detergent
- Rinse-aid

 Both powder and liquid products are available; only choose **low foaming industrial products**.

 Some detergents are age and temperature sensitive; these must not be stored for too long or in very hot or cold ambient temperatures.

 *Detergents and rinse-aids are potentially hazardous chemical products.* **NEVER immerse you bare hands in the washing solution**; use protective gloves when necessary. In case of contact with eyes, rinse with copious amounts of running water and seek medical assistance, indicating the type of detergent..

II Checking the machine

⚠ Before starting the machine, check that it has been installed correctly by a qualified technician in compliance with all the indications contained in the documentation supplied with the appliance.

⚠ Dispensers for rinse-aid and detergent (optional)

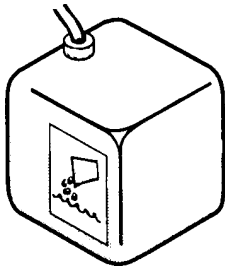

Before starting the wash cycle, the dispensers and the dispensing pipes must be full.

Check the levels of rinse-aid and detergent and top up if necessary.

Never allow the rinse-aid and detergent containers to empty completely. Do not top up with corrosive or impure products.

⚠ The warranty does not cover any damage or injury arising from the incorrect use of dispensers.

3. *First cycle*



1. Turn on the external water stop cock.
2. Connect the power supply to the appliance by operating the external main switch.
3. Set the machine to “wash” mode by pressing switch [1]. The wash chamber will automatically start to fill.



For appliances without detergent dispensers only.

Add detergent in the region of the pump suction filter every 5 cycles in the amount recommended by the manufacturer. An average dosage might be 1-2g/litre for powder detergents or double this amount for liquid products. On first filling, and then at each subsequent changing of the washing solution (at least three times per day), the dosage must be sufficient for the amount of water in the chamber plus that used in the next five rinses, as indicated in the section “installation data”. For subsequent dosages only add the detergent required for the rinses.

4. Load the items to be washed into the racks: use racks suitable for the type of item (long-stemmed glasses, tumbler, cups, ordinary plates, large plates, cutlery, etc.) without overloading.

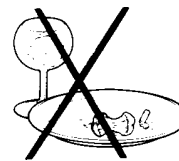
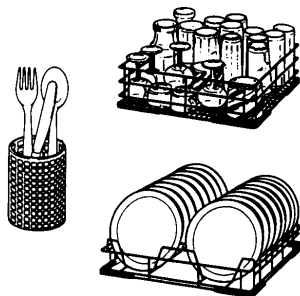

5. Remove large food particles; do not load dishes with dried-on or solid residue.

USE AND MAINTENANCE

6. Only load items which are guaranteed suitable for dishwashers and which are free from cracks.



7. Load the rack into the appliance and close the door.

8. Select the desired cycle with button [7]. Press button [2] to start the wash cycle.



9. Light [3] will illuminate to indicate that washing cycle is in progress.



 If the door is accidentally opened during the washing cycle, the machine will stop immediately. To resume the cycle from the point at which it was interrupted, simply re-close the door.



Even though the cycle will stop immediately if the door is opened accidentally, some splashes of alkaline washing solution may be thrown out of the appliance.



10. L Pilot light [3] switches off to indicate that the washing and rinsing phases have been completed.



For appliances with the “cold rinse” option only.

If washed items are to be used immediately and require a cold rinse (beer glasses, ice cream dishes), press button [5] for 10 - 20 seconds to perform a further rinse cycle using fresh water drawn directly from the mains supply without heating.

11. Remove the rack immediately from the appliance to allow the items to dry properly.

12. When removing the tray, tilt it slightly to allow excess water to drain from the dishes.

13. Leave the dishes in the rack for a few seconds to allow the last drops of water to evaporate.

14. Remove the items from the rack. Ensure that your hands and the surfaces where the items are placed are perfectly clean to prevent contamination of the washed items.

4. *Subsequent cycles*

Check the washing solution; if it is too dirty or the filters are clogged with residue from previous washes:

- empty the wash chamber as described in the section “Emptying the machine”;
- clean the machine as described in the section “Maintenance”;
- renew the washing solution. **The washing solution must in any event be renewed at least three times per day.**

USE AND MAINTENANCE

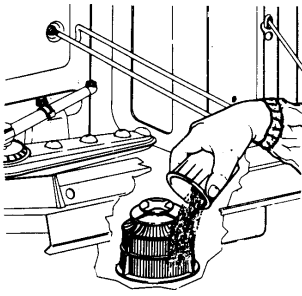

For appliances without detergent dispensers only.

If five cycles have already been performed, add detergent in the region of the washing pump suction filter in the amount indicated by the detergent manufacturer and the installation manual.

Follow the instructions given for the first wash cycle from point 6 “Load the items to be washed into the racks” onwards.

5. *Emptying the machine*

I Appliances without drain pumps



Switch off the machine at the power on/off switch [1].

Remove the overflow plug from the machine and wait until the chamber is completely empty before proceeding to clean as described in the section “Maintenance”.

II Appliances with drain pumps

To drain the machine:

I. Clean the filters.



II. Remove the overflow plug.

III. Press the “drain pump” button [6] to drain, releasing it when the chamber is empty.

6. *Before the daily shutdown*

- Remove the overflow plug and empty the machine as described in the section “Emptying the machine”.
- Clean the machine as described in the section “Maintenance”.



- Switch the machine off at the power on/off switch [1]

-  **Disconnect the power supply to the machine** at the external main switch.

-  **Turn off the external water stop cock.**

- Leave the door slightly ajar to prevent unpleasant odors forming in the chamber.

7. *Maintenance*

I Daily maintenance



The following operations are to be carried out **two or three times a day** when residue accumulates around the chamber filter.

- **Drain** the water off completely as described in the section “Emptying the machine”.

-  **Disconnect the power supply at the external main switch.**

-  **Turn off the external water stop cock.**

- Remove the racks, filters and overflow plug from the chamber.

USE AND MAINTENANCE

- Clean the machine using a damp rag with a little detergent.
-  **Do not use** scouring pads, wire brushes or abrasive cleaning products to clean the steel surfaces.

If the machine is not to be used for a period, leave the door slightly ajar to prevent unpleasant odors from forming.

II Periodic maintenance

The following operations are to be carried out **every two or three days**, after routine maintenance.

Remove and clean the wash and rinse arms as shown below:

- Unscrew the ring nut and pull off the wash and rinse arms.

Thoroughly clean the chamber and the machine, using a non-abrasive disinfectant product.

Refit the nozzles and arms, taking care to insert the arms properly in their respective mountings.
Refit all the filters.

III Major maintenance

Once a year, or whenever limescale deposits are noted in the machine, call a **specialist technician** to:

- Remove limescale deposits from the chamber and heating elements.
- Dismantle and thoroughly clean the wash and rinse arms/nozzles.
- Check the condition of the seals and other components subject to wear such as pumps, dispensers, level switches and programmers and replace parts when necessary.
- Adjust the settings of the rinse-aid dispenser and detergent dispenser (optional).

 When the appliance is to remain **idle for a long period**, apply Vaseline oil to the steel surfaces and call a **specialist technician to prepare the water circuits and the dispensers for storage.**



 If you suspect that **ice** may have formed in the appliance, **DO NOT USE IT** until a qualified technician has inspected the boiler and the pipes.

8. Regeneration

I Procedures

Some models are equipped with built-in water softeners.

Machines with this optional accessory require **periodic regeneration of the ion-exchange resins.**

The frequency with which this operation is to be carried out can be determined from the attached table **in accordance with the hardness of the water** in the your area and the **number of cycles** performed.



- P Press switch [1] to turn off the machine (pilot light off).
- Empty the machine as described in the section “Emptying the machine”.
- Clean the machine as described in the section “Routine maintenance”

USE AND MAINTENANCE

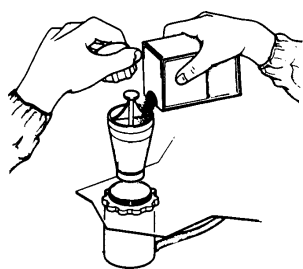

- Open the regenerating salt container inside the wash chamber.
- Pour about 250g of regenerating salt into the container (use cooking salt without additives with grains 1 or 2 mm in diameter).
- Replace the container cap and screw tightly into place.



- Press button [2] until pilot light [3] illuminates.
- The regeneration cycle starts and will last for approximately 20 minutes.



- Termination of the regeneration cycle is indicated by the switching off of pilot light [3].

NOTES:

We suggest that regeneration is carried out at times when the dishwasher is not in use.

On completion of the regeneration cycle it is advisable to:

- remove the overflow plug;
- close the door;



- start the machine by pressing switch [1]
- leave the machine on for about 1 minute to remove any residual salt;
 - switch off the machine and replace the overflow plug.

In areas where the water hardness is below 14 French degrees (°fH), the built-in water softener is only advisable if you wish to obtain a reduction in detergent consumption.

⚠ In areas where the water hardness exceeds 35 °fH French degrees, we strongly recommend the installation of an external water softener of suitable capacity (8 - 12 liters).

II Built-in water softener regeneration table

dH	F	N° of cycles
6	10	150
6.5	11	138
7	12	126
7.5	13	114
8	14	102
8.5	15	90

dH	F	N° of cycles
13	23	56
13.5	24	53
14	25	50
14.5	26	47
15	27	44
15.5	28	41

USE AND MAINTENANCE

9	16	77
9.5	17	74
10	18	71
10.5	19	68
11	20	65
12	21	62
12.5	22	59

16	29	38
17	30	35
17.5	31	32
18	32	29
18.5	33	26
19	34	23
19.5	35	20

9. Solutions to the most common problems

I Dishes not clean

PROBLEM	REMEDY
Wash arms stuck.	The arms should rotate easily by hand. Pull arms off and clean carefully. Check and clean the arms supply pipe in the machine.
Nozzles of spray arms obstructed	Remove the spray arms and clean carefully to remove obstructions.
Nozzles of rinse arms clogged with limescale	Pull off the rinse arms and descale in a separate container. Check that the water softener is operating correctly (if fitted).
Too much or too little detergent.	Check detergent dosage, referring to relative section in this manual.
Filter clogged	Remove, empty and clean filter
Wash cycle too short.	Select a longer cycle if possible, or repeat the cycle.

II Dishes not perfectly dry

PROBLEM	REMEDY
Too little rinse-aid	Increase dosage (see instructions).
Grease or starch not completely removed	Too little detergent. Increase dosage as per instructions in relative section of this manual.
Wrong type of detergent	Choose a more effective product.
Washing solution too dirty.	Drain the wash chamber, clean filters and chamber. Remove more residue prior to washing.
Rack unsuitable for type of tableware.	Use a suitable rack and allow water to drain from tableware.
Tableware left in machine after cycle has finished.	Remove from machine immediately after the cycle finishes to allow to dry.
Glassware surface rough and porous, or opaque through corrosion.	Renew glasses and use suitable racks. Glasses should be prevented from coming into contact with each other during the wash cycle.
Streaks and spots on tableware.	Too much rinse-aid. Reduce the dosage (see instructions).
Water too hard or containing too high a concentration of dissolved minerals.	Ask local water board for information about water quality and compare with values indicated on the machine's data plate

USE AND MAINTENANCE

III Water softener

PROBLEM	REMEDY
Excess salt in rinse water.	Salt left in container after regeneration. Only fill container immediately before starting the regeneration cycle with the quantity of salt indicated in the operating instructions.
	Wrong size salt grains. Use salt with a grain size of 1 - 2 mm
Excessive salinity after resin regeneration.	External water softener. Rinse the resin at the end of the regeneration cycle, draining the water container in the water softener.
	Built-in water softener. Salt container cap not fully tightened. Open container, remove salt using hot water, replace cap and screw on tightly..
Limescale deposits in machine	Regeneration not performed correctly at right time. perform two or three consecutive regeneration cycles, adding salt each time.
	Descale the machine.
	Water supply filter clogged. Clean or, if necessary, replace with a higher capacity filter.

IV Miscellaneous problems

PROBLEM	REMEDY
Tableware broken by impact during wash cycle.	Use suitable racks for the type of tableware and do not overload.
Machine stops in middle of cycle.	Machine interconnected with other appliances. Provide separate power supply for the machine with a switch or fuses suitably rated for the current indicated on the data plate.
	If the problem recurs, have the system checked by a qualified electrician.
Machine fails to start after a period of inactivity.	Have a qualified technician turn the pump motor over using the splines on the opposite end of the shaft to the pump impeller.
The cycle does not stop when the door is opened.	Have a qualified technician repair the door safety switch and check the magnetic contact and its circuit.

SERVICING AND REPAIR

1. *Safety notes*



- **NEVER** remove the panels from the machine without having first **disconnected the electrical power supply and turned off the water supply.**
- **NEVER** operate the machine **without the protections fitted by the manufacturer** (microswitches, panels, etc.) unless under the supervision of a qualified technician who has taken the necessary precautions.
- In the case of service/repair operations which require the removal of the safety panels **always wear safety gloves** to protect against possible crushing, bruising or cuts, which are always possible when handling sheet steel, even with carefully smoothed edges.
- On completion of the service/repair operations, **replace all protections,** reset the safety sensors and take care not leave foreign objects inside the appliance.
- Always refer to the **technical documentation** accompanying the machine (electrical circuit diagram and layout) and the values indicated on the data plate.

2. *Resetting the safety thermostat*

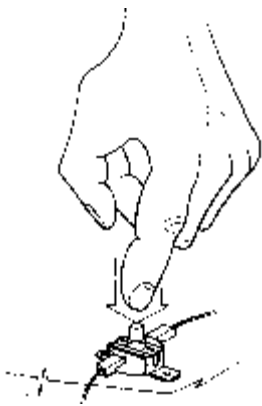

The machine is equipped with two safety thermostats, one on the boiler and one in the chamber, which trip to disconnect the power supply to the heaters in the event of overheating.

To restart the machine after one of the thermostats has tripped, first remove the cause of the problem, then press the red reset button.

3. *Renewal of the peristaltic dispenser pipe (optional)*



The pipe of the peristaltic detergent dispenser is a part subject to wear, due to the combined action of the chemical agents and the mechanical stresses. The pipe must therefore be periodically renewed, at intervals which depend on the conditions of use (number cycles performed, type of detergent used, ...).

Remove the transparent cover

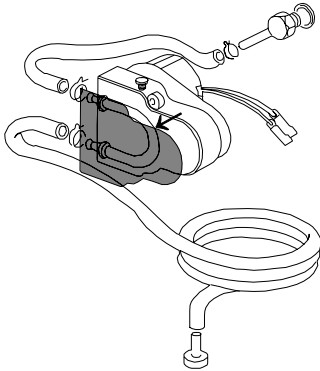

Detach the silicone pipe by turning the gear wheel

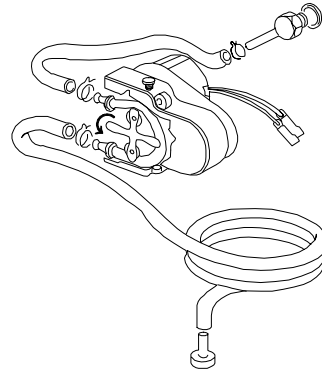

Renew the silicone pipe

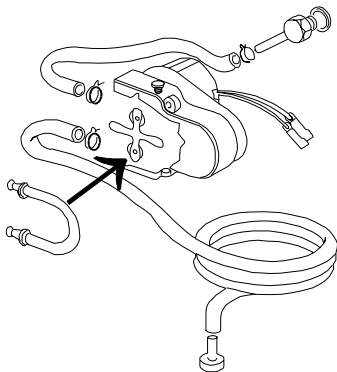

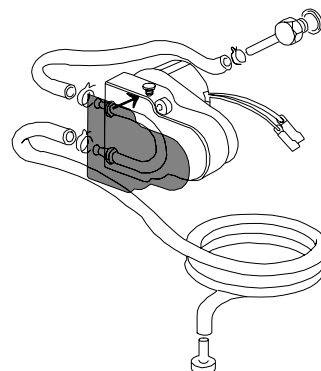

Replace the transparent cover



DEINSTALLATION

 **Deinstallation of the appliance should be carried out by qualified and authorized technicians only** who must:

-  **Disconnect the power supply** to the machine at the external main switch.
-  **Close the external stop cock.**
- Empty, clean and completely prepare all the internal water circuits, the pumps and the boiler to prevent the formation of ice and bacterial propagation.
- Clean the dispensers with clean water and glycerin (50%-50%), making sure that they are internally clean and lubricated.
- Disconnect the machine completely from the electrical power supply and the water supply.

To prepare the machine for transportation, remove and pack separately all the moveable parts indicated in the section “Maintenance”.

 **Transportation of this appliance should only be entrusted to specialized carriers** who have the trolleys, materials, and tools required for packaging and handling of loads fixed to standard pallets and who are capable of providing a service to professional standards.